



KT33.03

MATTE BLACK & CHROME MIXER

Product



Features

- Square laundry kitchen mixer
- Solid brass, chrome & matt black finish
- 360° swivel spout, wide flat surfaces
- Classy modern, hides finger prints
- Drip free ceramic cartridge technology
- WELS Star rating: 6 star, 4.5L/M
- Easy to install
- 10 years replacement products and parts.
- 2 years labour.
- *Needs 70mm to rear of splashback or window sill

Accessories Included

- 1 x Hot & cold hose
- Installation fittings

Power Specifications

Pressure rating: Maximum operating pressure 1000kPa. Note: For best performance and longer life we recommend 300-800kPa

Temperature rating: Maximum hot temperature 80°C, minimum 5°C

Dimensions

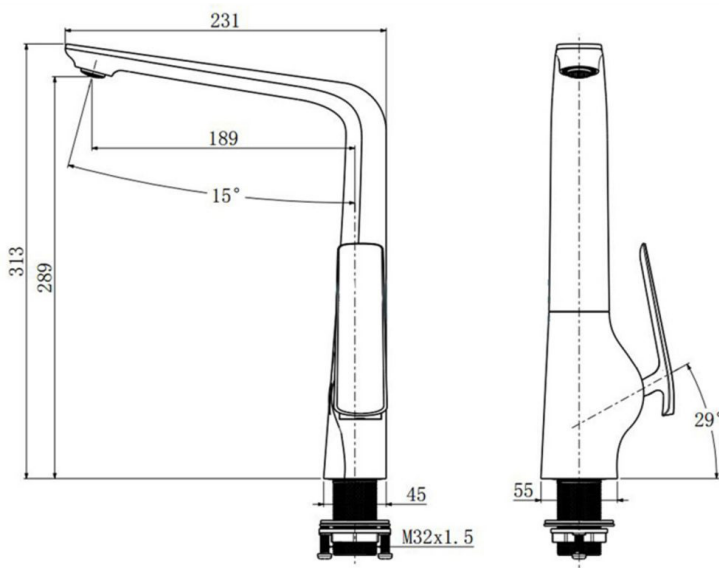

Product Dimensions

Cartridge Size 35mm
 Base Size 50mm
 Hose Length 500mm

Installation Information

A suitably qualified plumber is required for installation. It is suitable that this tap is installed directly through a solid bench top or a top mounted sink.

Please note:

Dimensions and specifications are a guide only refer to the instruction manual for full instructions. Every effort has been made to ensure this information is correct. However, due to product improvement Daniela Appliances reserves the right to make changes to products without prior notice.